

# Elkhart Musical Instrument Co. William J. Gronert

Elkhart, Indiana

- 1851 William Joseph Gronert is born in Hastings, England (*The New Langwill Index*).
  - 1865 Gronert enlists in British army as musician; serves 9 years (*NLI*).
  - 1874 Gronert emigrates to the US and joins the 17<sup>th</sup> US Infantry as a musician.
  - 1880 Gronert is a musician living in Elkhart and boarding with instrument maker Jacob Berkley (census).
  - 1881 Gronert marries Alice in Elkhart in January. Daughter Geraldine is born in October in Chicago.
  - 1884 Daughter Charlotte is born in November in Elkhart.
  - 1885 Gronert joins Conn and becomes his factory manager.
  - 1900 William C. Reid (1875-1963) is a machinist in Elkhart (census).
  - 1910 Reid is a music shop owner and Gronert is a factory manager (census).
  - 1911 The Elkhart Musical Instrument Co. is founded. Gronert president, Reid secretary & treasurer. 916-920 Prospect St. Incorporated in June with \$25,000 capital (*MTR*).
  - 1912 Gronert is granted design patent #D43276 on Nov. 26<sup>th</sup> for a cornet matching his "Masterpiece Grand" model (photos 1-3). Reid is granted patent #1,023,330 on April 16<sup>th</sup> for a piston valve guide (assignor to EMI Co).
- Robert Middleton (b.1878 in Scotland) files on 3/19 for a trombone tuning device with assignment to Elkhart MIC.
- 1913 Middleton is granted patent #1,060,779 for his tuning device (below).

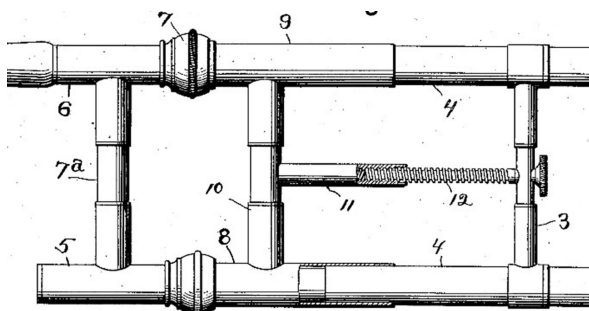
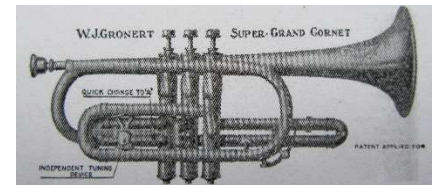
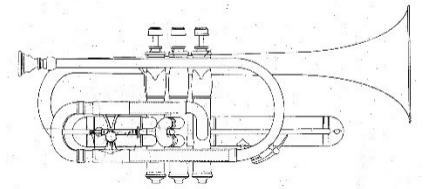
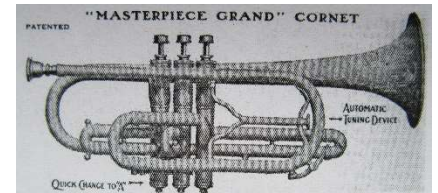
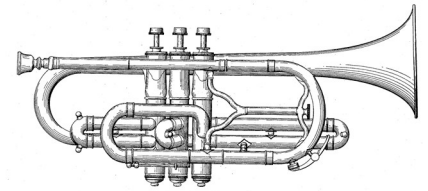

1916 Harry Pedler quits Conn and starts the American Manufacturing Co. with William J. Gronert, #430 Baldwin St, Elkhart (see map page 3).

1916 Gronert's lawsuit with Conn from four years ago is settled in January. He had been seeking \$150,000 but the final terms were not disclosed. This came about from an early agreement for Conn to pay Gronert \$0.50 for every instrument produced under his management (*MTR*).

1916 Gronert & Reid are granted patent #1,171,191 for a building block. On Oct. 10<sup>th</sup> they are granted patent #1,201,039 for a tuning slide matching that on the "Super Grand" model. Reid's son William T. is working for them.

1916 A four-valve "Invincible" model cornet #2069 is marked "Patent Allowed July 9, 1913" which does not fit with any known patent granted (photos 3-5). These have a 4<sup>th</sup> valve that locks down for a key change to A.

1917 EMI Co. merges with Martin and Gronert becomes GM.

1919 Gronert dies in July. The American Mfg. Co. is re-named the Harry Pedler & Co c.1920: woodwinds only. Gronert's obituary lists him as Martin Band Instrument Co.'s GM and secretary.

1920 Reid is listed as a horn maker (census; probably for Martin).

1939 Reid is still listed as a band instrument maker.

1963 Reid dies in Elkhart (obit.).

**Instruments Found:** photos from Horn-u-copia & auctions

Cornet #1296: Gronert Masterpiece Grand model (photos 1&2), c.1915. This is marked "Patent Jan 13, 12" which is unknown & has designs from both 1912 & 1916 patents.

Cornet #1318 (below)



Cornet #612 (photo 7): Elkhart MICO

Instruments with the same designs can be marked either Gronert or Elkhart MICO.

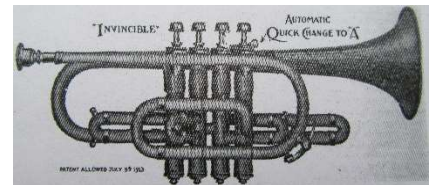
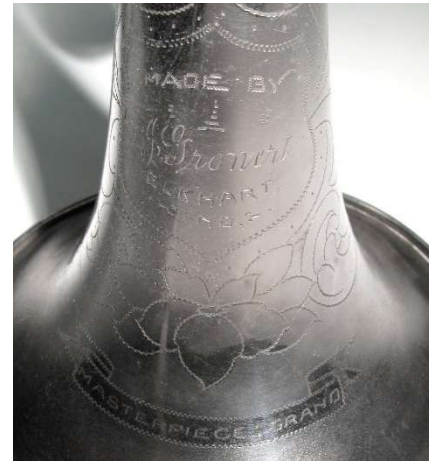

#916 Prospect Street Factory in 1917

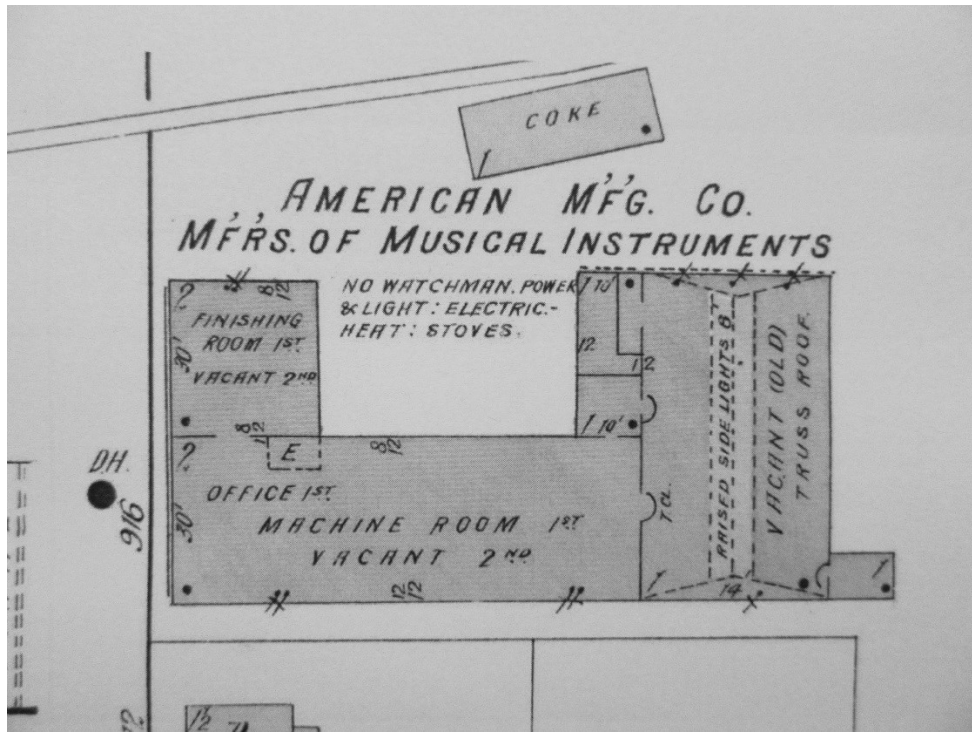

#430 Baldwin Street Factory in 1927 opposite Martin

